

Extracting S-Parameters with SPICE

Wes Hayward, w7zoi, April 2007

A computer analysis of a circuit using SPICE can easily be used to extract scattering parameters. The circuit is shown below.

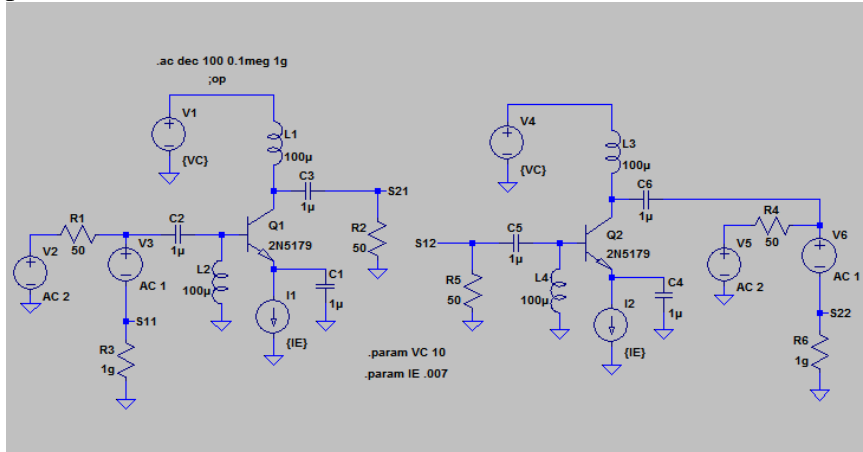

The constant current source (duplicated) is set for a current of I_e in the “.param” statement, here 7 mA. This sets the emitter current. A pair of voltage sources set the collector voltage for the transistor.

The next figure shows S11 versus frequency for this example.

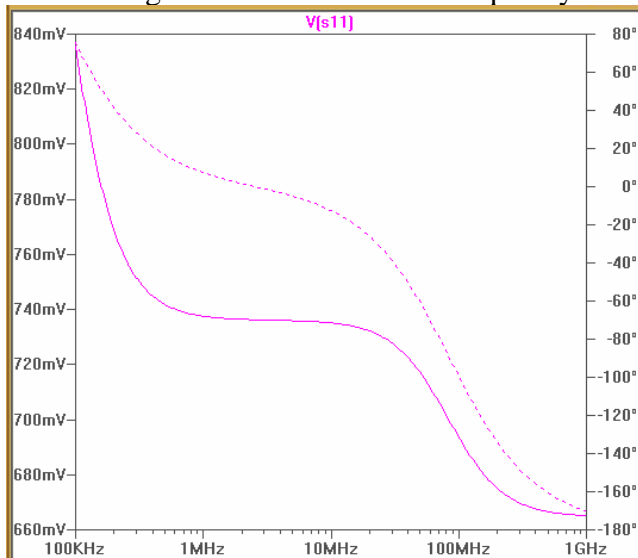

If we zoom in on this graph, we can grab the values at 50 MHz. We would see $S_{11}=0.717$ at -60.7 degrees. This is just a voltage reflection coefficient, so translation tells us that the input impedance is $29.9-j76.9$ Ohms. (I used MicroSmith to extract this data, but it can be done from fundamentals.)

I used the SPICE program offered by Linear Technology for this example. Many thanks to LT for this wonderful offering found on the web.